

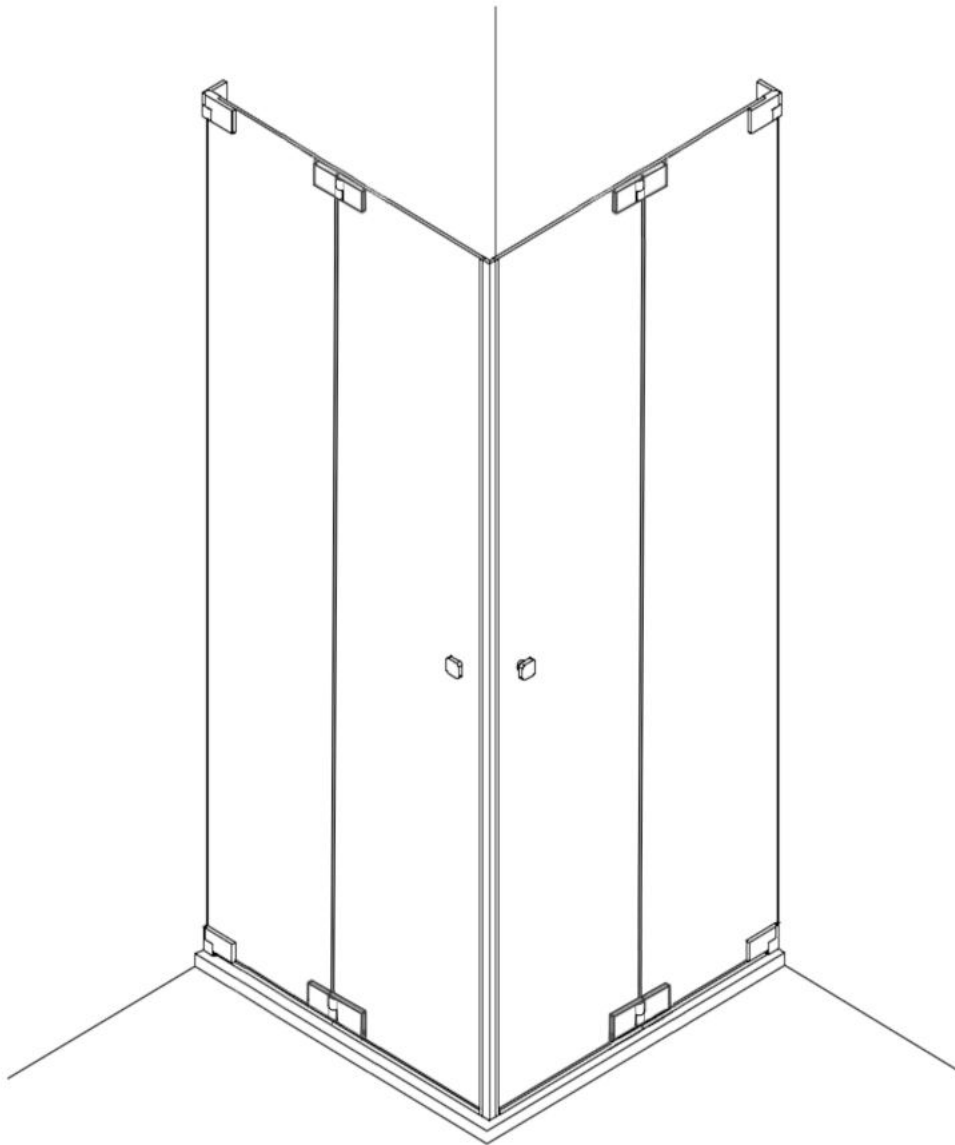























# GF1W, HF1W, MGF1W

## Montageanleitung Installation Manual



Eckdusche mit 2 Falt-Türen  
Corner shower enclosure with 2 folding doors

- |              |   |              |   |           |   |  |   |
|--------------|---|--------------|---|-----------|---|--|---|
| 1 x G/GAS-RO |  | 1 x G5/G5H   |  | 12 x G100 |  | 8 x   | 1 x  |
| 1 x G/GAS-RU |  | 2 x G8F/G8FH |  | 12 x G300 |  | 8 x   | 1 x  |
| 1 x G/GAS-LO |  | 4 x G10      |  | 4 x G301  |  | 12 x  |   |
| 1 x G/GAS-LU |  | 2 x G7/G7H   |  | 2 x G400  |  | 1 x G150   |      |
| 1 x G/WS-RO  |  | 1 x G/WS-LO  |  |           |   | 8 x F1   |      |
| 1 x G/WS-RU  |  | 1 x G/WS-LU  |  |           |   |  |   |

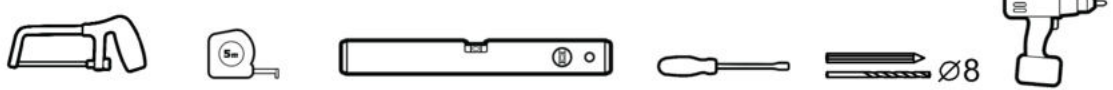
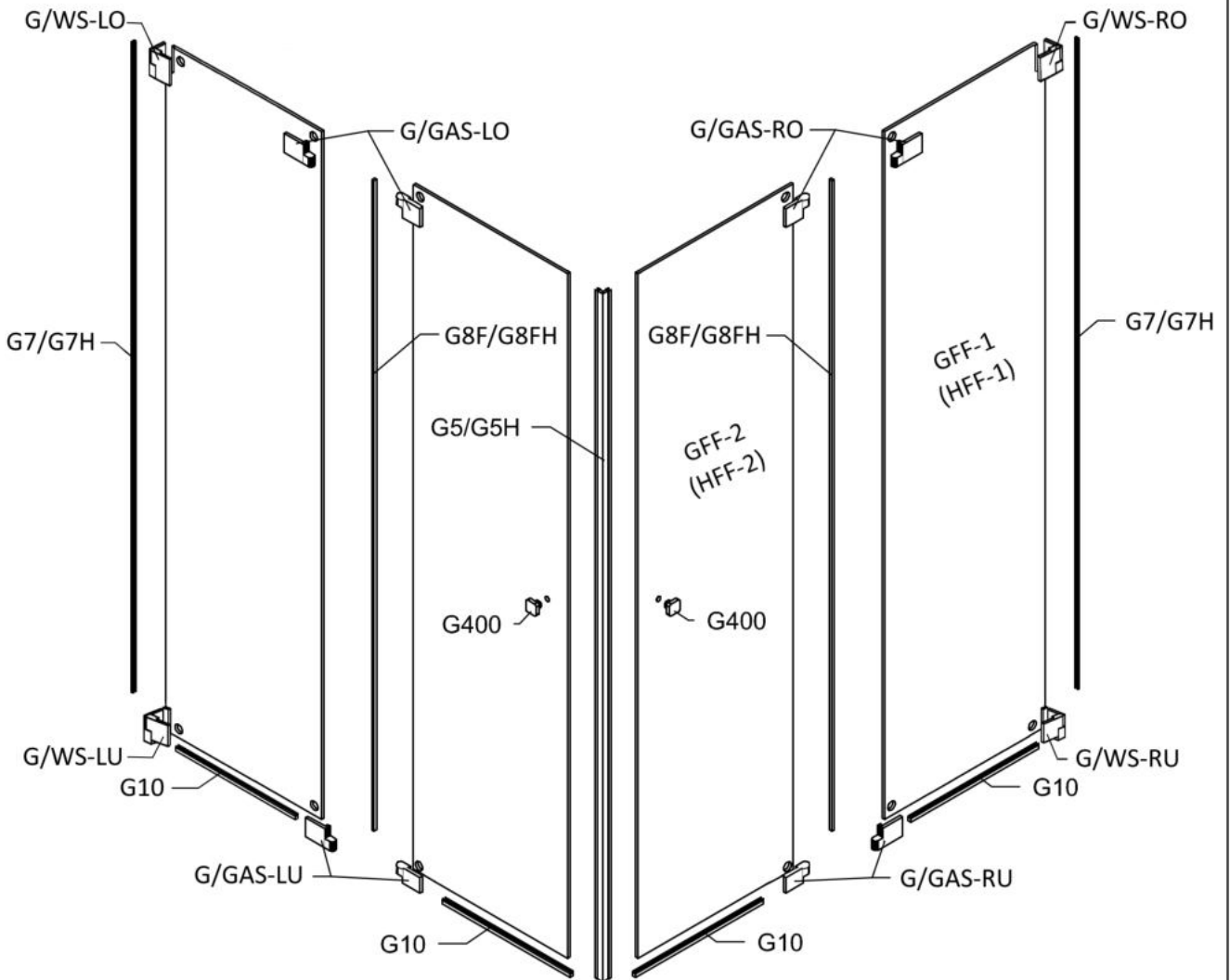



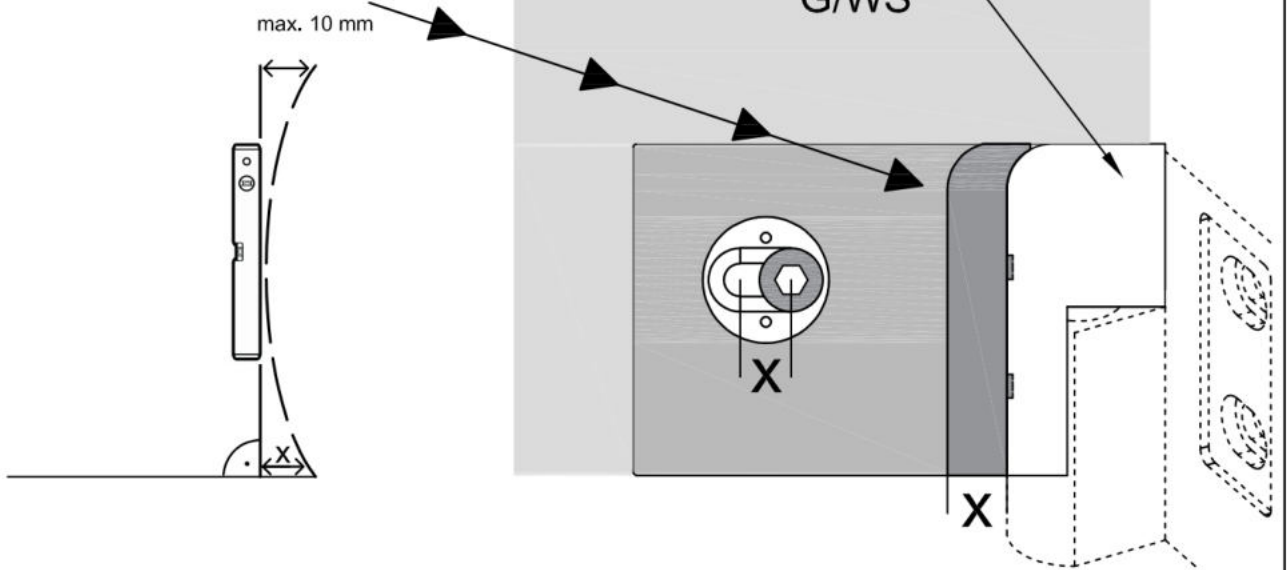
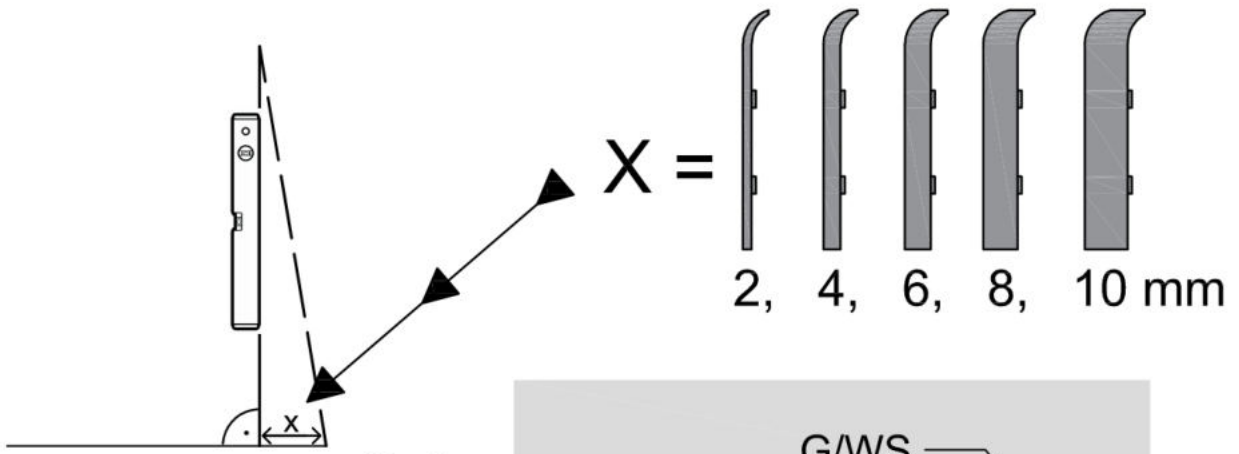
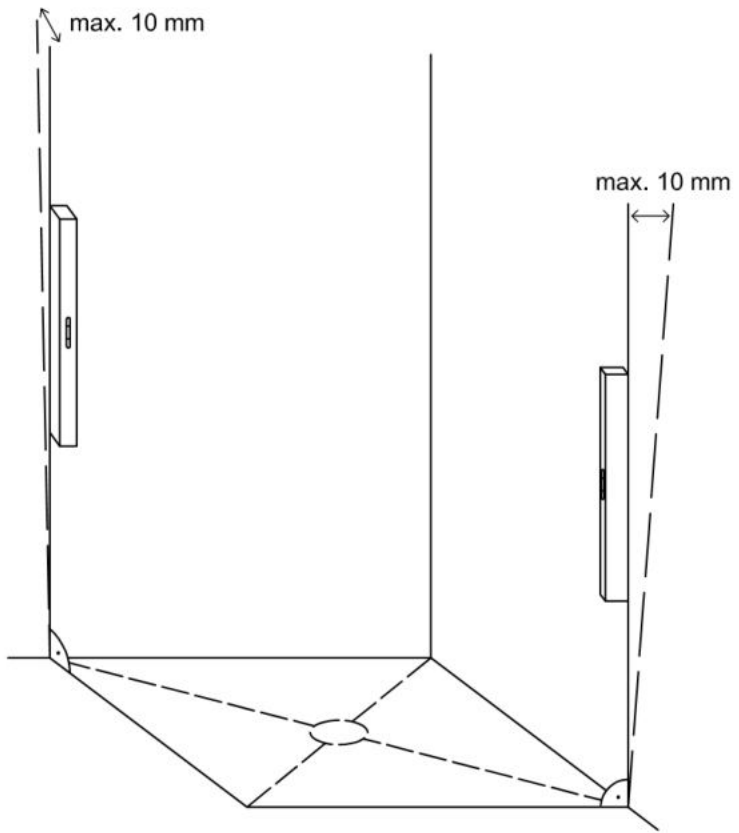
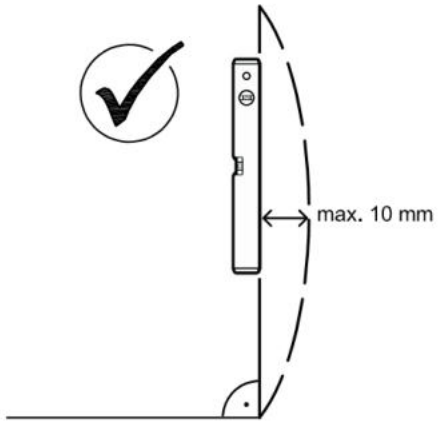
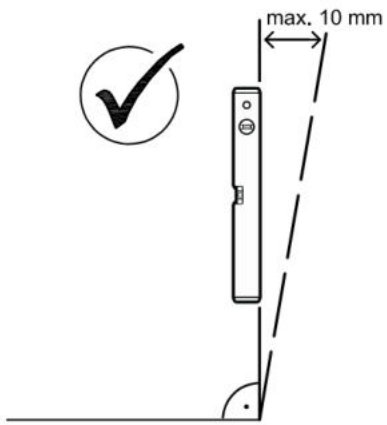

## Vormontage von Dichtprofilen und Beschlägen Pre-assembly of gaskets and fittings.

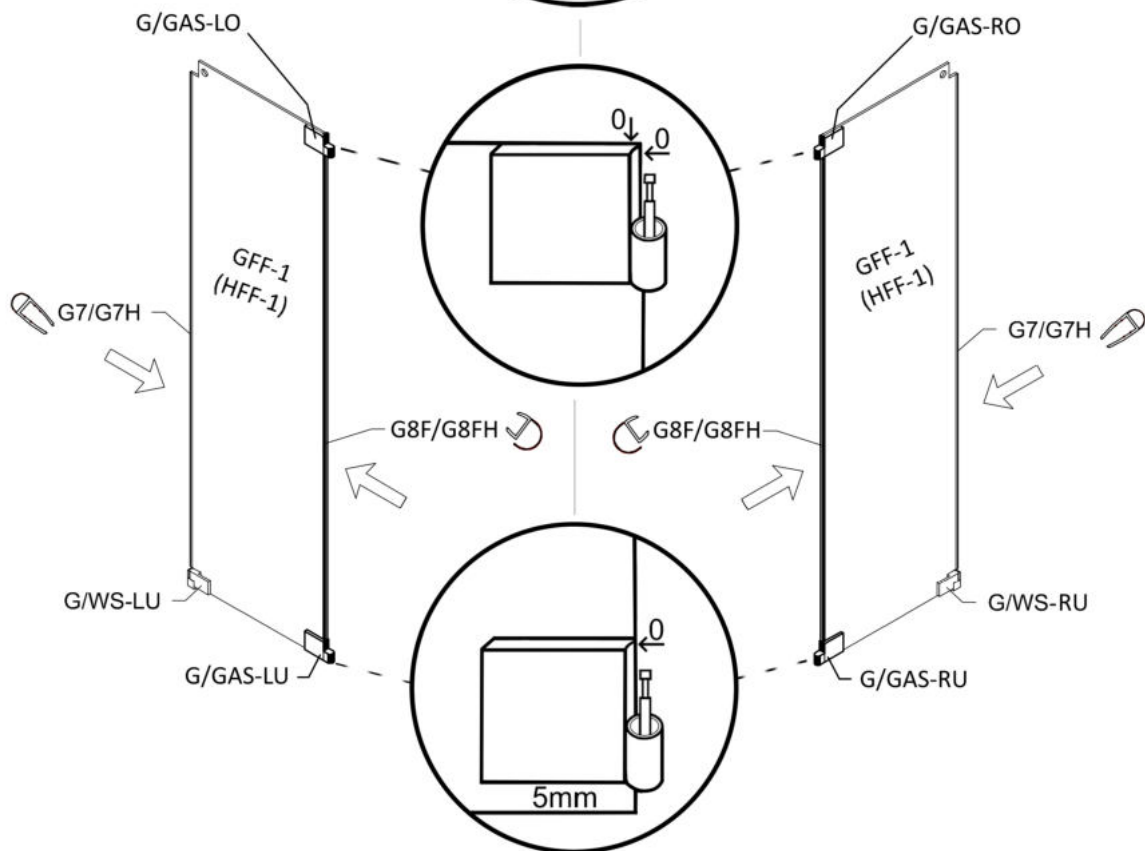
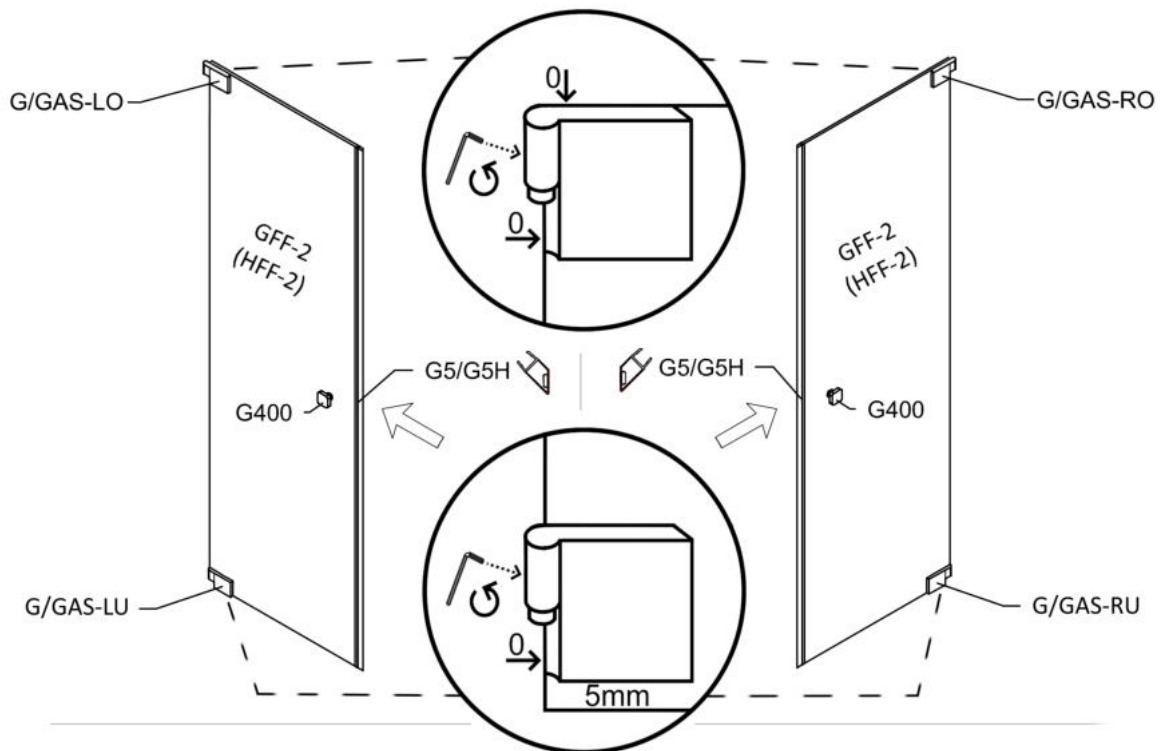

Die Scharniere müssen vor dem Einhängen korrekt positioniert auf die Glasteile montiert werden und mit ca. 9 Nm Drehmoment angezogen werden.

The hinges must be mounted on the glass panels in the correct position before installation and tightened to a torque of approximately 9 N·m torque.

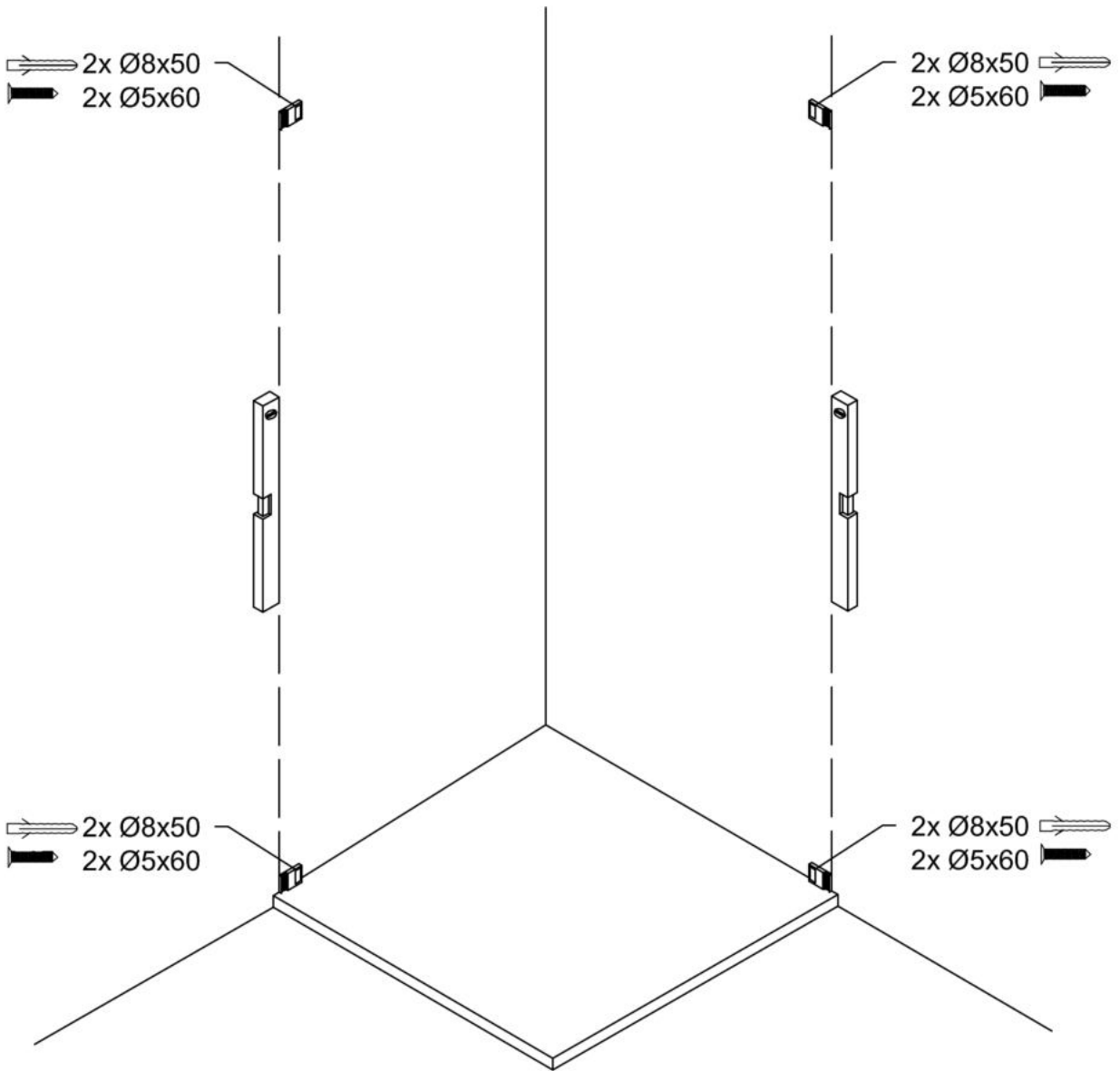

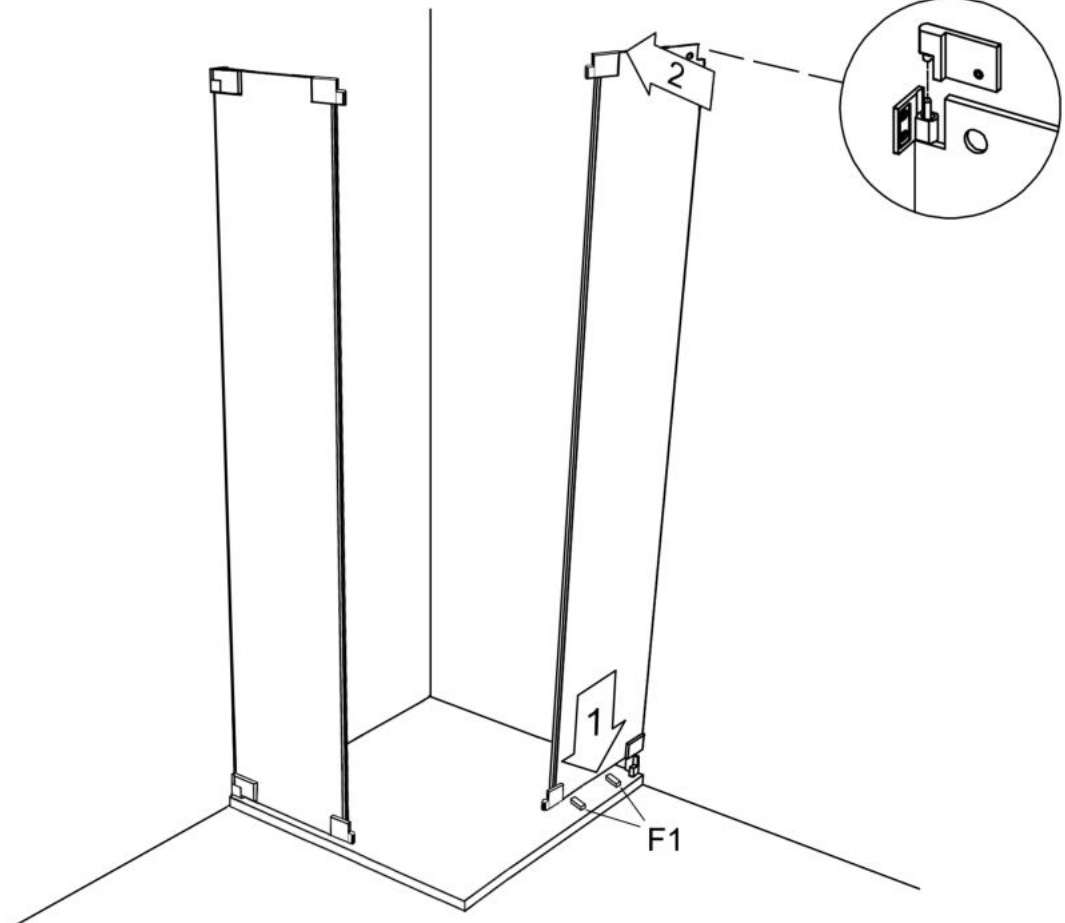
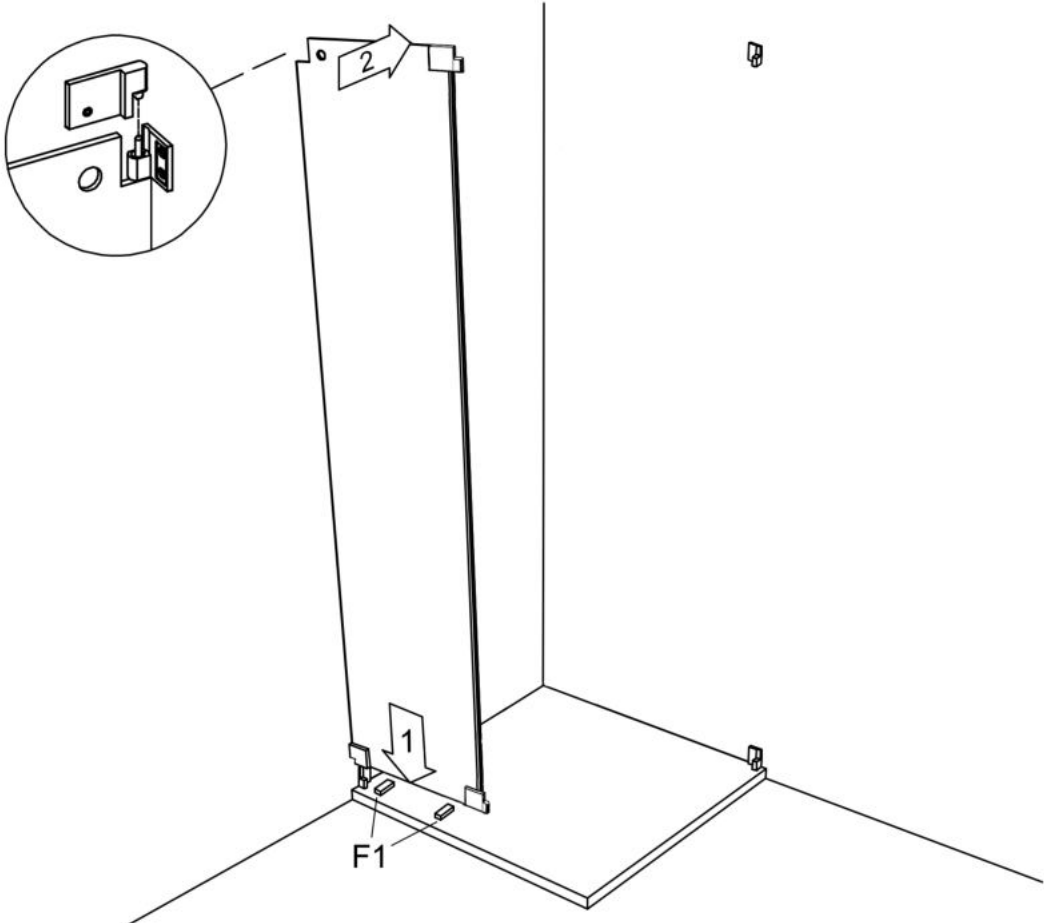

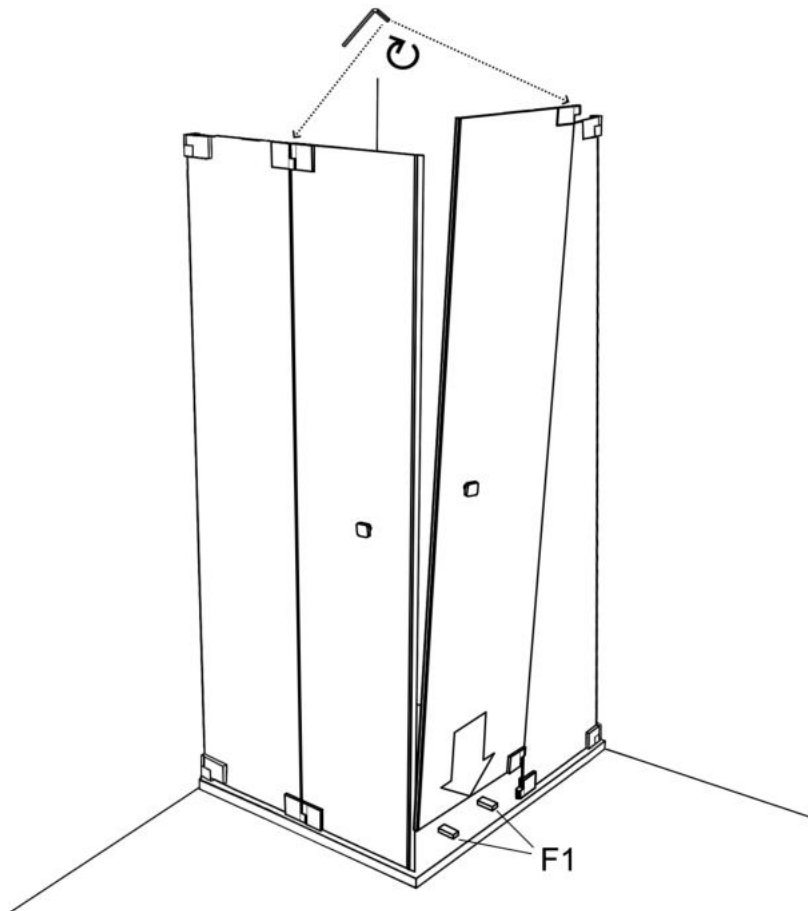
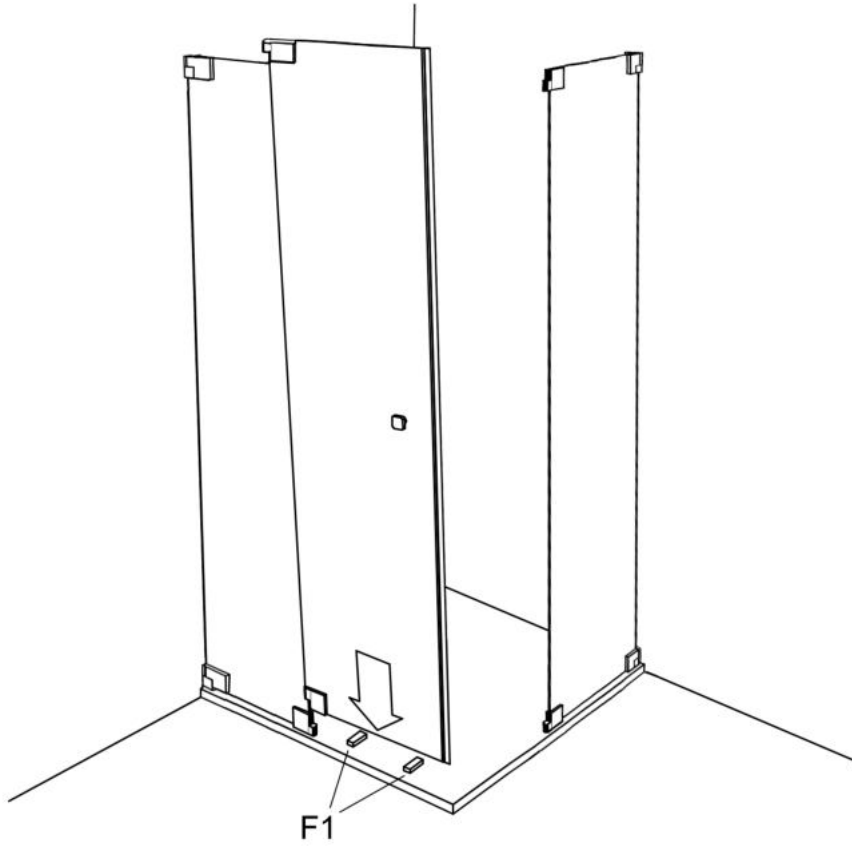

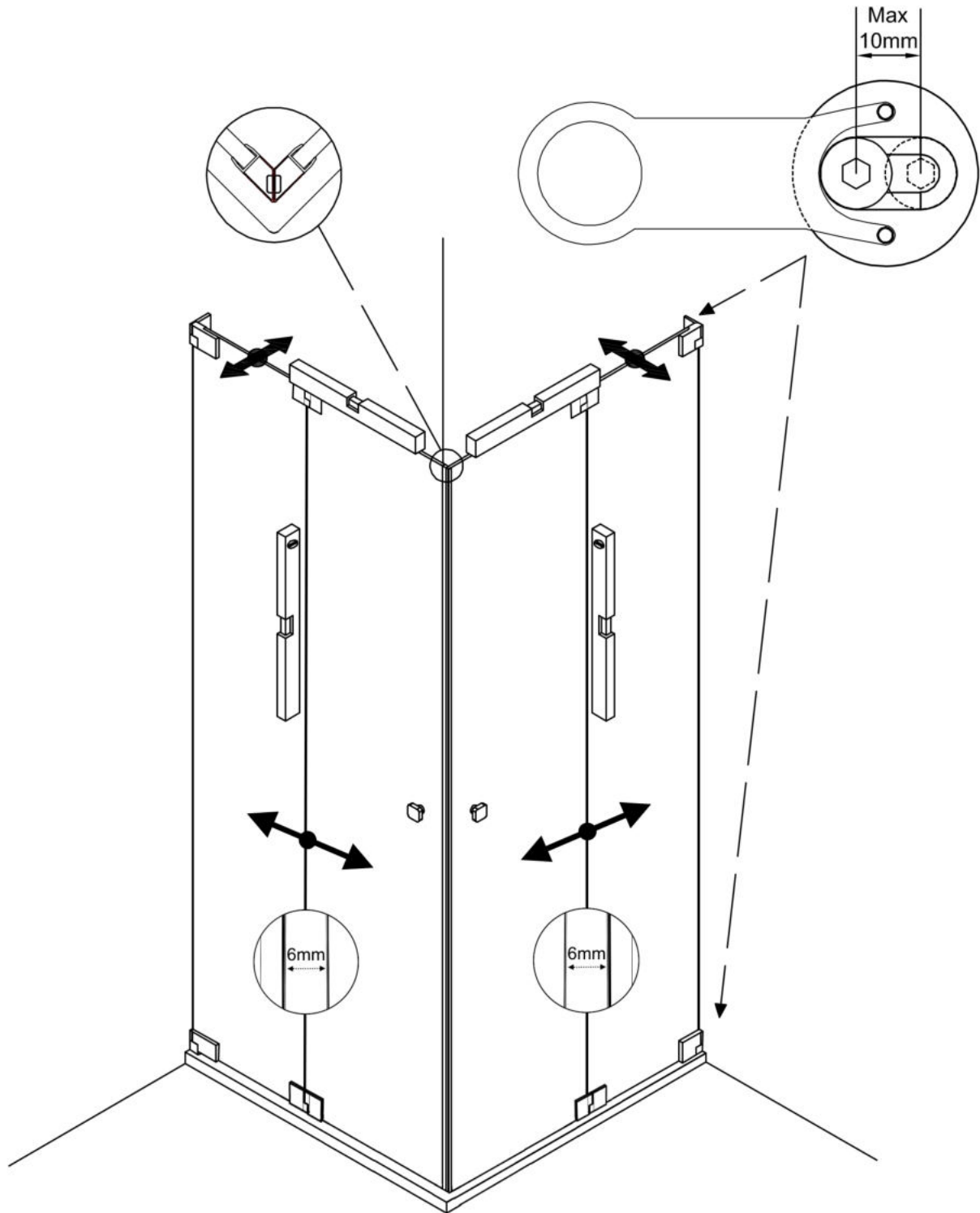

Richten Sie die Glas-Türe senkrecht aus und fixieren Sie die Inbus-Schrauben in den Langlöchern der Glasbefestigungen. Mit dem Montage-Schlüssel können die Glasbefestigungen dabei waagrecht gehalten werden. Schieben Sie dann das Tür-Kompensationsprofil (G7 / G7H) auf dem Glas an die Wand, so dass die Fuge zwischen Wand und Türe mit dem Balg leicht an der Wand anliegend gleichmäßig geschlossen wird.

Set up the glass door vertically and fix the Inbus screws in the slotted holes of the glass fixings. By using the installation key the glass fixings can be kept horizontally. Slide the compensation gasket (G7 / G7H) on the glass against the wall to close the gap between wall and door evenly with the bellows soft to the wall.

